

Issue Date: 07/17/2017

Page: 1 of 5

File: PSS-K656LR-W0X

15/25kV	600A Deadbreak Elbow	w/ Test Point	K656LR-W0X
---------	----------------------	---------------	------------



Features:

- Fully rated 15/25kV, 600 Amp Deadbreak Elbow
- Fully shielded, fully submersible molded rubber housing
- 100% peroxide-cured construction includes insulation and conductive EPDM materials
- Can be easily connected or disconnected using standard hand tools and equipment in a de-energized state
- Optional accessories allow visible external separation, by-pass, isolation, dead-ending, grounding, and testing as well as adding taps, surge arrestors, and fault current indicators
- Non-corrosive, capacitive test point

K656LR Elbow Connector (with Test Point)

Applications:

The Elastimold® K656LR (with test point) is designed to provide fully shielded, dead-front submersible cable connections to high-voltage apparatus. The K656LR can be used through 28kV with conductor range from #2 AWG to 1250 kcmil for aluminum and copper conductors and insulation diameters from .640" to 1.935". When used on metallic tape shield or drain wire cable, an ECS cable seal grounding device for safety is highly recommended.

Ratings:

Meets ANSI/IEEE Standard 386, Latest Revision

For 15kV Voltage Class:

8.3kV Max Phase-to-Ground – Operating Voltage

14.4kV Max Phase-to-Phase

95kV BIL – Impulse Withstand (1.2 x 50 microsecond wave)

34kV AC – One minute withstand

53kV DC – 15 minutes withstand

11kV AC – Corona Extinction @ 3pC sensitivity

600 Amp – Continuous

25kA Sym – 10 Cycles Momentary

For 28kV Voltage Class:

16.2kV Max Phase-to-Ground – Operating Voltage

28kV Max Phase-to-Phase

140kV BIL – Impulse Withstand (1.2 x 50 microsecond wave)

45kV AC – One minute withstand

84kV DC – 15 minutes withstand

21.5kV AC – Corona Extinction @ 3pC sensitivity

600 Amp – Continuous

25kA Sym – 10 Cycles Momentary

15/25kV	600A Deadbreak Elbow	w/ Test Point	K656LR-W0X
---------	----------------------	---------------	------------

Product Selection:

Step 1 (W)

Determine the insulation diameter of the cable.
 Select the insulation letter code that best straddles the insulation diameter from W table below. Insert code into catalog number.

Step 2

Choose the proper connector material type and insert it into the catalog number.

Step 3 (X)

Choose the proper compression lug code according to the conductor size from the Conductor Code Table. Insert code into catalog number.

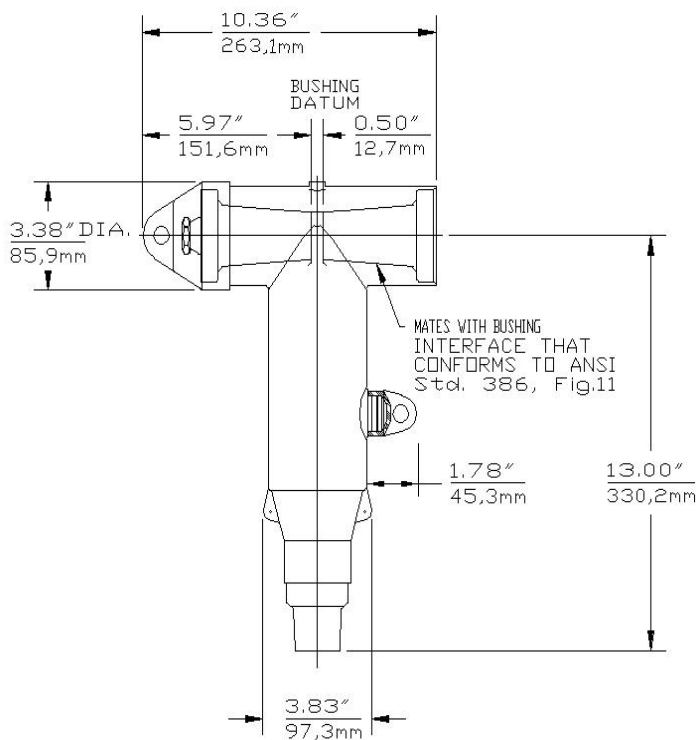

Example:

The ordering number for a 600 Amp Elbow Connector for a 4/0 compacted, 175 mil wall cable with an insulation diameter of .830\" to .910\" and test point is **K656LR-G0270** plus the sealing kit, based on the shielding type. See next page.

For 900A Elbows Use the Part # K676LR-G2270

Each kit contains the following:

1	Elbow connector housing	K656BLR
	AI -Universal compression	
1	lug	03700XXX
1	Stud	650SA
1	Insulated Plug w/ Cap	K650BIP
3	Tube, lubricant	82-08
1	Cable adapter	655CA-W
1	Installation Instruction	IS-0230
1	Installation Instruction	IS-0320
1	Crimp chart	CC-0050

15/25kV	600A Deadbreak Elbow	w/ Test Point	K656LR-W0X
---------	----------------------	---------------	------------

IMPORTANT:

For safety purposes, a sealing & grounding kit installed with the 600A dead break is **RECOMMENDED**. Please choose the sealing and grounding kit below.

Jacket Concentric Neutral Cable

Copper Tape Shield Cable

200/600ECS

200/600ECSG3

For Jacketed Concentric Neutral Cables, the sealing kit part number will be:
200ECS or add suffix “-S” to part number for cables with nominal O.D. within the range of .80”-1.50”
600ECS or add suffix “-S” to part number for cables with nominal O.D. within the range of 1.28”-2.30”

For Copper Tape Shield Cables, the sealing & grounding kit part number will be:
200ECS or add suffix “-S” to part number for cables with nominal O.D. within the range of .80”-1.50”
600ECS or add suffix “-S” to part number for cables with nominal O.D. within the range of 1.28”-2.30”

Example:

The ordering number for a 600 Amp Elbow Connector for a 4/0 compacted, jacketed concentric neutral, 175 mil wall cable with an insulation diameter of .830” to .910” , with test point, and overall cable diameter is 1.23” and capacitive test point is **K656LR-G0270-S**.

Example:

The ordering number for a 600 Amp Elbow Connector for a 4/0 compacted, copper tape shield, 175 mil wall cable with an insulation diameter of .830” to .910” , with test point, and overall cable diameter is 1.23” and capacitive test point is **K656LR-G0270-S**.



15/25kV	600A Deadbreak Elbow	w/ Test Point	K656LR-W0X
---------	-----------------------------	---------------	-------------------

Unishield Cable

10TL-W



For Unishield Cables, the shield adapter part number will be: **10TL-W**, where the "W" letter code will be determined by the insulation diameter of the Unishield cable. Please see W Table below for W code. Or add suffix "-TL" to the part number.

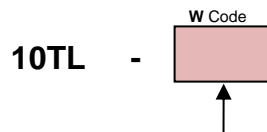

Cable Insulation Diameter in Inches		Cable Insulation Diameter in mm		Symbol for W
MIN.	MAX.	MIN.	MAX.	
0.495	0.585	12.6	14.9	EB
0.525	0.635	13.3	16.1	EF
0.575	0.685	14.6	17.4	FA
0.625	0.735	15.9	18.7	FAB
0.675	0.785	17.1	19.9	FB
0.725	0.835	18.4	21.2	FG
0.775	0.885	19.7	22.5	GA
0.825	0.935	21.0	23.7	GAB
0.875	0.985	22.2	25.0	GB
0.930	1.040	23.6	26.4	GH
0.980	1.115	24.9	28.3	HA
1.040	1.175	26.4	29.8	HAB
1.095	1.240	27.8	31.5	HB
1.160	1.305	29.5	33.1	HJ
1.220	1.375	31.0	34.9	JA
1.285	1.395	32.6	35.4	JAB
1.355	1.520	34.4	38.6	JB
1.485	1.595	37.7	40.5	KA
1.530	1.640	38.9	41.7	KAB
1.575	1.685	40.0	42.8	KB
1.765	1.875	44.8	47.6	PB

Example:
 The ordering number for a 600 Amp Elbow Connector for a 4/0 compacted, Unishield, 175 mil wall cable with an insulation diameter of .830" to .910" , with test point, and overall cable diameter is 1.23" and capacitive test point is **K656LR-G0270-TL**.

Copper Tape Shield Cable



Example:
 Partial installation example of **K656LR-G0270-SG3** for copper tape shield cables. For full instruction please see IS-460.

Concentric Neutral Cable



Example:
 Partial installation example of **K656LR-G0270-S** for concentric neutral cables. For full instruction please see IS-459.